

LUBRICATE ALL SEALS WITH CLEAN HYDRAULIC OIL PRIOR TO ASSEMBLY.
DO NOT USE SILICONE BASED LUBRICANTS.

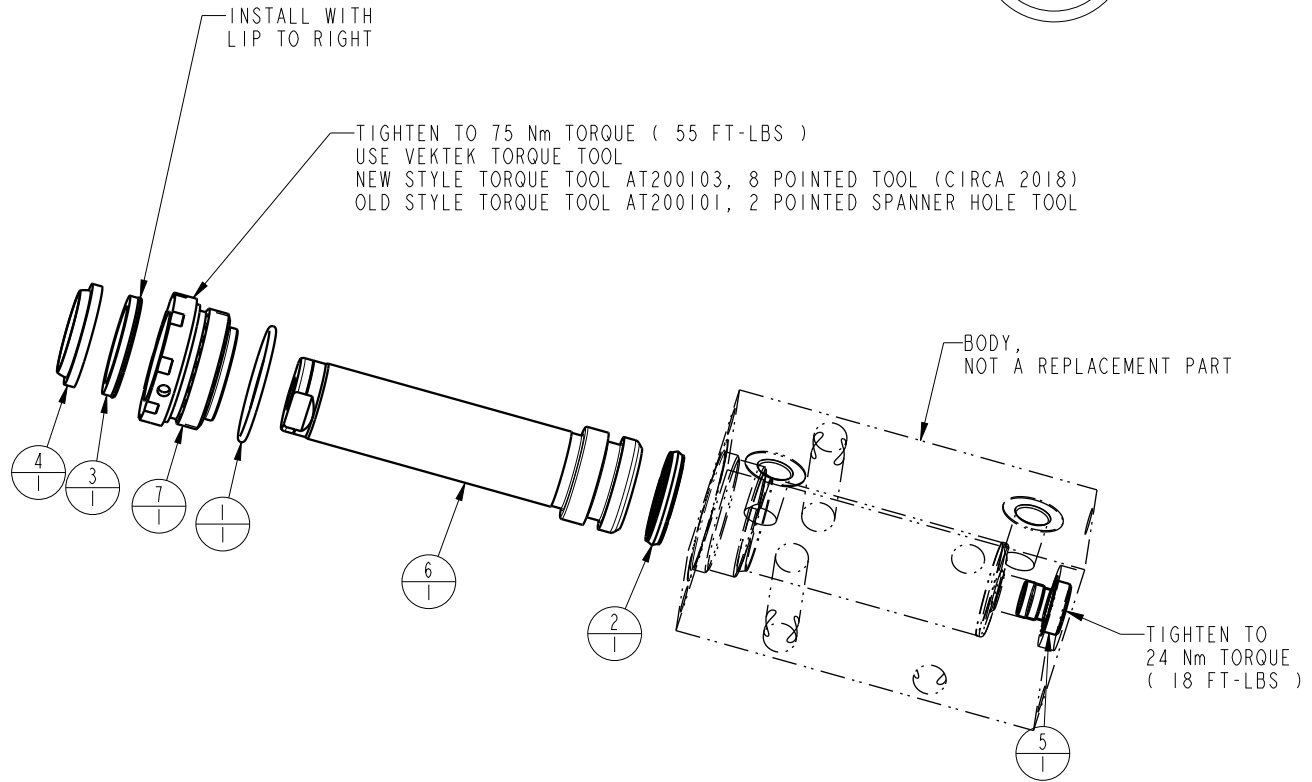

N/A	N/A	6V200209	KIT, SEAL, FKM	N/A	NOTED
N/A	N/A	46000032	KIT, SEAL, STANDARD	NOTED	N/A
7	1	82031002	GLAND,CYL, 3900 & 17.8 KN		
6	1	48011002	PISTON,CYL,17.8 KN,51 STRK		
5	1	43068004	PLUG, 1/8 BSPP		
4	1	39012008	WIPER,SNAP-IN, (13/16)	X	X
3	1	39011045	SEAL, LL, (13/16 X 1/8 X 1/8 X 1-1/16)	X	39012005
2	1	39010017	SEAL,CROWN,13/16x1x5/32	X	39V10017
1	1	39001011	O-RING, (-024)	X	39012013
No.	QTY	PART No.	DESCRIPTION	Standard Seal Kit	FKM Seal Kit

PARTS LIST



VEKTEK, INC.
1334 E. SIXTH AVE. P.O. BOX 625
EMPORIA, KS. 66801 U.S.A.

ASSEMBLIES AFFECTED
42012004

PARTS LIST, ASSY,CYL,BB,17.8KN,51 STRK,DA

SIZE
A MPL2056

REV
J

SHEET 1 OF 1

J	4249	RELEASE	JDW	08/13/20
REV	IN ACCORDANCE WITH ECN	EFFECTIVE DATE	REVISED BY	DATE
DRW BY:	BUSH	DRAWING STATUS: Released		
DATE:	12/15/94	PRODUCTION APPROVED FOR RELEASED STATUS ONLY		

FORM FEG035_PL_ASIZE, REV. B